

BUCKET LOADER



SPECIFICATIONS 72" BUCKET

NON-SELF LEVELING

MECHANICAL SELF LEVELING

A	Maximum lift height at pivot pin (mm/in)	3430	3430
B	Maximum lift height under bucket in level position (mm/in)	3149	3149
C	Dump clearance (mm/in) at 60° (mm/in)	2597/102	2597/102
D	Digging depth (mm/in)	162/6.4	162/6.4
E	Reach at maximum lift at 45° (mm/in) Reach at maximum lift at 60° (mm/in)	958/37.7 727/28.6	958/37.7 727/28.6
F	Reach at ground level (mm/in)	2263/89	2263/89
G	Bucket rollback angle	45°	45°
H	Bucket dump angle	60	60
I	Bucket rollback force at maximum height (kg) Bucket struck capacity (m ³) Bucket heaped capacity (m ³) Bucket weight (kg)	2462 0.454 0.584 183	2462 0.454 0.584 183
Lift capacity maximum height at pivot pins (kg/lbs)		2075/4574	2250/4960
Lift capacity maximum height at 800 mm (kg/lbs)		1315/2899	1710/3770
Boom breakout force at pivot pins (kg)		3087	3257
Boom breakout force at 800 mm (kg)		2098	2768
Bucket rollback force at maximum height (kg)		2462	2934
Bucket rollback force at ground level (kg)		3823	4393

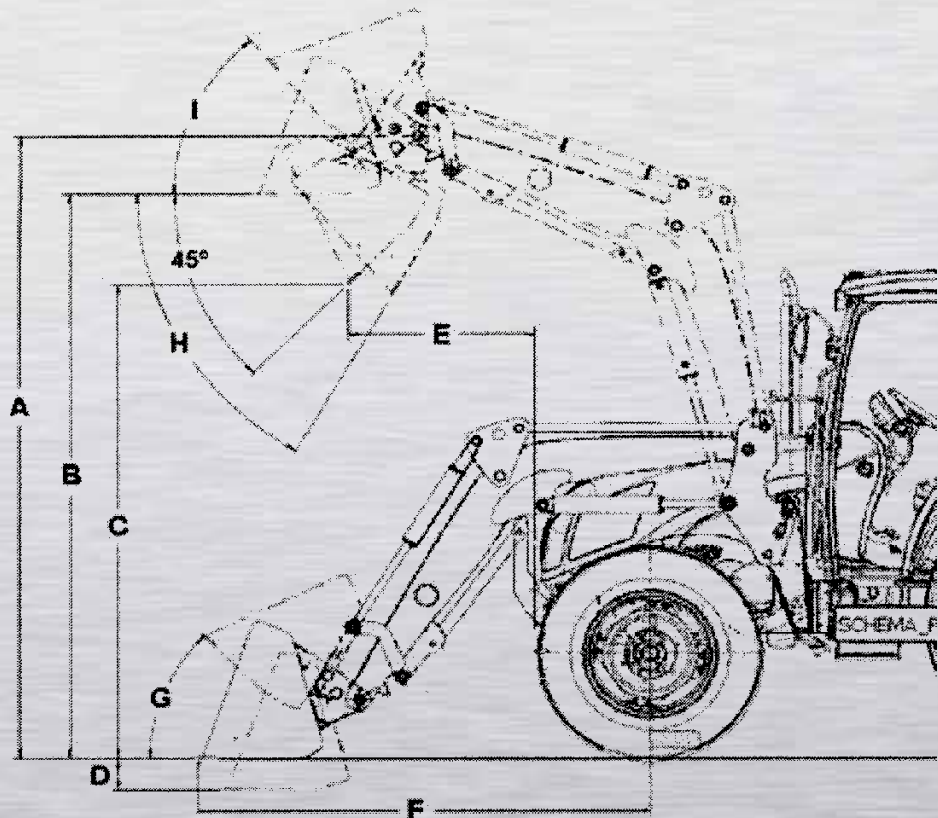

NOTE: Specifications may vary, confirm with your dealer.